



VIBRATION SENSOR NODE (SD-VSN-3)

The SmartDiagnostics® family of innovative wireless sensor products enables cost-effective predictive maintenance for industrial equipment. The system provides continuous remote monitoring of key performance indicators to track the operating health of equipment.

- Optimized for long battery life
- Full time series data sets up to 5 times per minute
- Expandable to hundreds of nodes per system



RELIABLE MONITORING	FLEXIBLE CONFIGURATION	COST EFFECTIVE
<p>Vibration Sensor Nodes provide health monitoring in the most hard-to-reach, rugged locations. Each node communicates via a direct wireless link to a Primary Receiver Node, from which the data is imported into SmartDiagnostics® Software for viewing and analysis.</p>	<p>The system is highly configurable and scalable. A system can have hundreds of sensor points, each of which can be configured to transmit data on a user-selected frequency, and unique indicators can be implemented to warn users of potential machine health issues.</p>	<p>Easily installed without the downtime, expense, and labor costs of old-fashioned, hard-wired sensors. Simply place the sensors where you need them and within minutes they'll transmit data. SmartDiagnostics® can predict failure before it occurs, saving money spent on unnecessary replacements and extending machine life. At the same time, energy costs are reduced, as properly maintained machines are more efficient.</p>

VIBRATION SENSOR NODE SPECIFICATIONS

Mechanical	
Weight	6.6 oz (188 g)
Enclosure Material	303 Stainless Steel and Radel R 5800
Mounting	1/4-28 internal thread; weld mount provision available; temporary magnet; & epoxy with lanyard
Certifications	UL, CE FCC CFR 47 Part 15 Subpart C Conforms to EN/UL/CSA/IEC 61010-1:2012 Ed.3 Conforms to ISA Std. 12.12.01 Certified to CSA Std. C22.2 No. 213
Environmental	
Storage Temperature	-40 to 238 °F (-40 to 120 °C)
Operating Temp.	-4 - 230°F (-20 - 110°C) surface @ 72°F (22°C) ambient -4 - 212°F (-20 - 100°C) surface @ 105°F (40°C) ambient -4 - 167°F (-20 - 75°C) surface @ 167°F (75°C) ambient
IP Rating	IP68, dust-tight and water-tight
Impact Resistance	Survives 5-ft drop onto concrete surface
Hazardous Certification	Class I, Division 2, Groups A-D, T5 (model SD-VSN-3N)
Use Case	For UL compliance: indoor use only
Exposure	Resistant to UV, petroleum products, mild acids and bases, cleaning products, most industrial fluids, most processing fluids
Wireless Radio	
Radio	KCF DART™ Wireless 2.4GHz ISM band FCC ID: Z5ISD3 IC: 24664-SD3 ICASA: TA-2022/0777
Range	800ft (240m) in open field 200ft (60m) in congested industrial space (site survey recommended for installation) Repeater SD-R adds up to 2400ft (730m) of range
Antenna	Internal dipole antenna
Power	
Power Source	3-Volt Lithium Manganese Dioxide (CR123A)
Battery Life	Full spectrum acquisition every: <ul style="list-style-type: none"> 60 minutes – 8 years 15 minutes – 6 years 2.5 minutes – 2 years Note: battery life is somewhat reduced at extremely cold temperatures
Accelerometer	
Range	+/- 19 g typical, +/- 16 g nominal
Resolution	0.866 mg nominal
Noise Floor	1.496 mg RMS @ 64 Hz / 13.01 mg RMS @ 8192 Hz
Transverse Sensitivity	10% Typical
Frequency Response	+/- 5% 0-2700 Hz, +/- 3 dB 2700-4000 Hz
Samples per Acquisition	4096 (standard) or 1650 (battery saver)
Spectral Lines	2048 (standard) or 825 (battery saver)
Anti-Aliasing Filter	4000 Hz low-pass cut-off, 3rd-order Sallen-Key
Sampling Frequency	64 Hz – 8192 Hz configurable (see table)
Temperature Sensor	
Range	-4 to 167 °F (-20 to 75 °C)
Resolution	+/- 1 °F (+/- 0.5 °C)

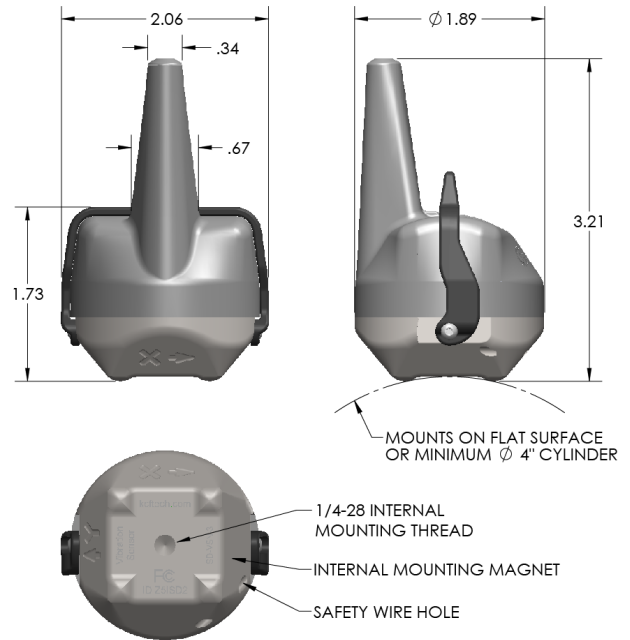

ACCELEROMETER SAMPLING

Sampling Frequency (Hz)	Sample Duration (s)	Spectral Resolution (Hz)
	Std. (batt. saver)	
8192	0.5 (0.2)	2.0 (5.0)
4096	1.0 (0.4)	1.0 (2.5)
2048	2.0 (0.8)	0.5 (1.24)
1024	4.0 (1.6)	0.25 (0.62)
512	8.0 (3.2)	0.13 (0.31)
256	16.0 (6.4)	0.063 (0.16)
128	32.0 (13)	0.031 (0.08)
64	64.0 (26)	0.016 (0.04)

CONFIGURATIONS

Part Number	Description
SD-VSN-3	Standard vibration and temperature sensor
SD-VSN-3N	Class I, Division 2 Certified vibration sensor for use in hazardous locations (US and Canada ETL #4008627)

FCC STATEMENT

This device complies with Part 15 of the FCC Rules. Operation is subject to the following two conditions: (1) this device may not cause harmful interference, and (2) this device must accept any interference received, including interference that may cause undesired operation. Changes Or Modifications Not Expressly Approved By The Party Responsible For Compliance Could Void The User's Authority To Operate The Equipment.